

The Italian contribution to the EXIST mission

L. Natalucci¹, G. Tagliaferri², P. Caraveo³, G. Pareschi², P. Ubertini¹, and G. Villa³

¹ Istituto Nazionale di Astrofisica – IASF-Roma, Via del Fosso del Cavaliere 100, I-00133 Roma, Italy, e-mail: Lorenzo.Natalucci@iasf-roma.inaf.it

² Istituto Nazionale di Astrofisica – Osservatorio Astronomico di Brera, Via Bianchi 46, I-23807 Merate, Italy

³ Istituto Nazionale di Astrofisica – IASF-Milano, via Bassini 15, I-20133 Milano, Italy

Abstract. The EXIST Mission is a proposed multi-wavelength observatory to carry out the most sensitive hard X-ray survey and census of SMBH as well as the most powerful follow-up of Gamma Ray Bursts (GRBs). This mission will carry a large area (4.5m²) CdZnTe modular detector with an angular resolution of ~ 2 arcmin, sensitive in the energy range 5-600 keV, and a near infrared telescope with cooled mirror with outstanding sensitivity and capability of measuring onboard the redshift of many GRBs. Italy will contribute to EXIST with the provision of a soft X-ray telescope sensitive in the energy range 0.1-10 keV with an effective area approximately equivalent to one mirror module of XMM-Newton. We will describe hereafter the characteristics and performance of this instrument together with its capability of performing serendipitous surveys.

Key words. X-rays: general – X-rays: telescopes – Space: instrumentation – Surveys: observations

1. Introduction

The EXIST concept based on a sensitive survey hard X-ray mission has been proposed several times, starting in the early 90's as a MIDEX (Grindlay et al. 1995). EXIST was one of the three recommended missions in the 2001 Decadal Survey, together with GLAST (now launched) and Con-X (that evolved into the IXO concept as a joint program by NASA, ESA and JAXA). The EXIST mission concept has actually much evolved from the earlier studies turning into that of a multiwavelength mission covering the IR/optical and soft/hard X-ray bands (see section 2). Recently, a one-year study has been funded by the

NASA/ASMC program, aimed at the preparation for a proposal to the Decadal Survey ASTRO2010. During this study, terminated in 2009 the Italian scientists currently involved in the INTEGRAL and Swift projects have been invited to contribute to EXIST, in particular for the provision of scientific instrumentation. The main contribution has been the concept of a Soft X-ray Imager (SXI), a substantially improved version of the Swift/XRT telescope, to be part of the EXIST mission payload. The SXI has been then successfully implemented in the baseline mission concept. Its design in a "pre phase-A" style is in progress thanks to the provision of an ASI grant following a competitive call for mission design studies.

EXIST responded to the latest call of Decadal Survey (ASTRO 2010) in

Send offprint requests to: L. Natalucci

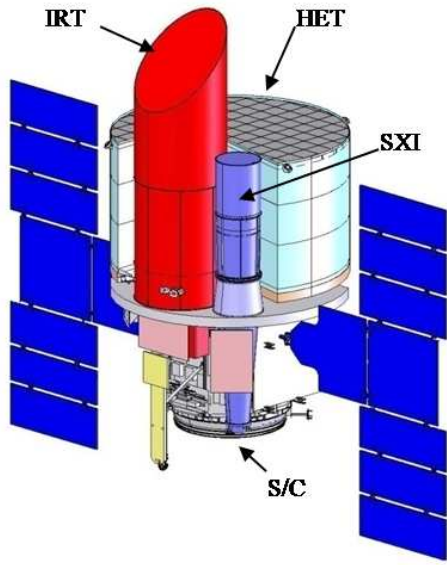

Fig. 1. The EXIST mission spacecraft with the three instrument complex: the High Energy telescope (HET), a large field-of-view (~ 90 deg) coded mask telescope and the Infrared Telescope (IRT) will be provided by the US whereas the Soft X-ray Imager (SXI) will be contributed by Italy (ASI).

February 2009 and to the related Request for Information (RFI) issued in July 2009. When fully funded, EXIST is scheduled for launch in mid 2017 with a EELV carrier (4m fairing). In this new configuration (see Fig. 1) EXIST will be able to study with unprecedented sensitivity the most unknown energy sources in the Universe, like the high redshift GRBs, which will be reprinted promptly by the Spacecraft by autonomous trigger based on the hard X-ray localization on board.

2. The EXIST mission

EXIST will be launched in a Low Earth Orbit (LEO) similar to the one of Swift and its primary instrument is the High Energy Telescope (HET), a wide field coded aperture instrument covering the 5-600 keV energy band and imaging sources in a 70×90 deg² field of view with ~ 2 arcmin resolution and better than 20 arcsec positioning (Hong et al. 2009). The energy band of HET overlaps with the soft X-

ray range covered by the proposed Soft X-ray Imager (SXI), 0.1-10 keV. The effective area of SXI is about 950cm² at 1.5 keV and its focal length is 3.5m (Tagliaferri et al. 2009). At longer wavelengths operates the IRT, an optical-IR aperture telescope covering the 0.3-2.2 micron range with variable spectral resolution and high NIR sensitivity (AB=24 in 100s). The IRT can obtain spectra of GRB afterglows up to $z \sim 20$ and make imaging and spectra of AGNs and transients discovered by the HET during the survey. The IRT pixel size is 0.15 arcsec and its Field-of-View in Imaging mode is 16 arcmin².

EXIST is a real multiwavelength observatory for observations of GRBs and Supermassive Black Holes (SMBH) as well as of many other types of transients and high energy sources.

The recent high energy surveys in particular by XMM-Newton (Watson et al. 2009), with its deep sensitivity in the soft X-ray band, INTEGRAL/IBIS (Bird et al. 2010) and SWIFT/BAT (Tueller et al. 2009) in hard X-rays have started to reveal in detail the demographics of sources in the near Universe. However, still far from being achieved are both a comprehensive picture of transient phenomena beyond GRBs and a deep study of the Supermassive Black Holes (SMBH) and of their host galaxies across Universe age. We note that EXIST will take advantage of the same concept of operability of SWIFT with ~ 10 times better survey sensitivity in the high energy band from 0.1 to 600 keV.

During the first two years of operation the EXIST observing time will be mostly devoted to survey and GRB follow-up while the following 3 years are predicted to be spent on pointed observations, taking full advantage of the presence of IRT and SXI. The first period survey will be performed by the HET pointing at the zenith with an offset of 30 degrees (towards the north and the south on alternate orbits, respectively) for an all-sky coverage each 3h. This will allow detailed studies of obscured AGNs and to further study the accretion luminosity of SMBHs, as well as an "ultimate sensitivity" survey for Gamma-ray Bursts (Grindlay et al. 2008).

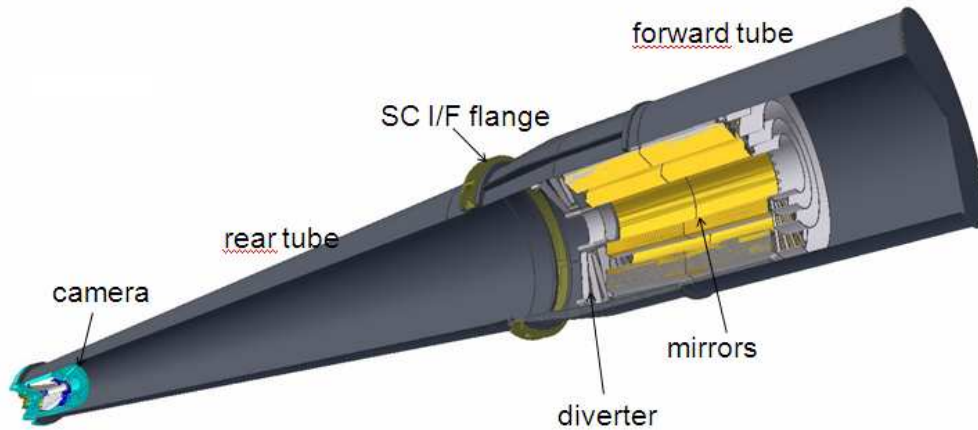

Fig. 2. View of the SXI instrument with details of parts (mirrors, camera and structure).

Table 1. Design parameters of the SXI telescope

Parameter	Baseline
Mirror	26 shells
Angular Resolution	20 arcsec at 1 keV
Energy Range	0.1-10 keV
Diameter of Mirror	60cm
Focal Length	3.5m
Detector Type	<i>pn</i> -CCD
Detector Size	3x3 cm ²
FOV	30x30 arcmin ²
Energy Resolution	130eV at 6 keV
Readout Speed	5-10 ms
Effective Area	950 cm ² at 1.5 keV, > 100 cm ² at 8 keV
Sensitivity (10 ⁴ s)	2 × 10 ⁻¹⁵ cgs

3. Design of the SXI instrument

The proposed design of the SXI (see Fig. 2 and Table 1) is based on a Wolter type-I telescope consisting of a main mirror assembly with 26 nested cells and a focal plane camera with CCD detector. The focal plane distance is 3.5m and the max.diameter of the mirrors is 60cm (giving 70cm on the telescope outer envelope). The telescope structure is built around an I/F flange in titanium which is the interface to the satellite optical bench. The effective area of the instrument is shown in Fig.3 and the main design parameters are listed in Table I.

3.1. The mirrors

A detail of the mirror system is shown in Fig. 4 (left panel). The mirror shells are grouped in two blocks in order to fulfill the desired effective area requirements. Possible space for improving the effective area at medium energies is available but this must consider weight constraints. A goal configuration with 38 NiCo shells instead of 26 has also been studied, based on thicknesses as low as those designed for the shells of Simbol-X. We have then evaluated the on- and off-axis (10arcmin) effective area of the optics for the baseline and goal configurations. This is shown versus energy in

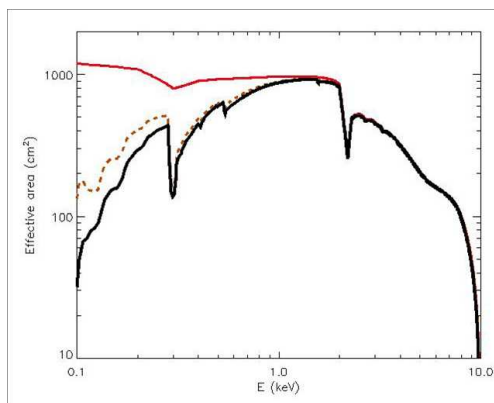

Fig. 3. The effective area of SXI (black). Also shown are the mirror effective area (red) and its convolution with an XRT-like transmission filter (brown).

Fig.4 (right panel). The values of angular resolution on- and off-axis have been also computed using a conservative model for integration errors. The Half Power Diameter (HPD) is estimated to be less than 20 arcsec throughout the whole field-of-view.

3.2. The detector and camera

The characteristics of the camera design (see Fig. 5) are very similar to those of the XRT and EPIC. In the current baseline the detector is a 3×3 cm² CCD sensor. Its Proximity Electronics is "suspended" within an Al shield and an active cooling system will ensure the optimal temperature for CCD operation. In order to operate efficiently during the HET survey mode the sensor is required to have a frame readout between 5 and 10 ms to compensate the relatively fast scanning. This can be achieved by the most recently developed CCDs as well as new generation detectors like the Active Pixel Sensors (Strüder & Meidinger 2008). The camera comprises other mechanical subsystems like the Vacuum Chamber, Filter Wheel and Vacuum Door. In the present design the Filter Wheel has 4 apertures, one of which is completely open, and one closed for CCD protection in case of high radiation. A third aperture consists of an X-ray filter to

reduce the optical/UV contamination. Finally, the 4th position consists of a closed position with a calibration source which illuminates directly the full detector in order to monitor its status, efficiency and the level of radiation damage.

4. SXI scientific performances

4.1. Survey sensitivity and coverage

During the zenith pointed scanning SXI will record X-ray events and the fast readout of its detector will allow to locate their direction. The coverage of this survey will be half the sky and the resulting average exposure time for a source is of the order of 200s/year, yielding a limiting sensitivity of $\sim 5 \times 10^{-14}$ erg cm⁻² s⁻¹ in two years. Since during the scanning the IRT does not operate, SXI will be able to improve the localization of many faint HET sources from ~ 1 arcmin to a few arcsec. On the other hand, during the second phase of the mission when EXIST is in pointing mode, SXI will help to obtain simultaneous coverage of the HET survey objects in the optical/NIR, soft X-ray to soft gamma-ray bands. In particular the SXI as well as the IRT will measure source intensities and spectra for the hard X-ray sources observed by HET down to a sensitivity limit of ~ 0.1 mCrab in the hard X-ray band.

Serendipitous surveys by SXI during the 3 years of the inertial pointing phase will allow to cover ~ 1500 square degrees down to the sensitivity limit of $\sim 2 \times 10^{-15}$ erg cm⁻² s⁻¹.

4.2. Study of individual objects

SXI will be very useful for broadband studies as it will extend the high energy coverage of EXIST by more than one decade in energy. This is of outstanding importance for the study of accretion phenomena in particular to determine the state and physical parameters of a high number of AGNs and Galactic Black Holes. Furthermore SXI, together with the IRT will help the optical identification and characterization of those sources detected by HET that are optically too faint to be matched

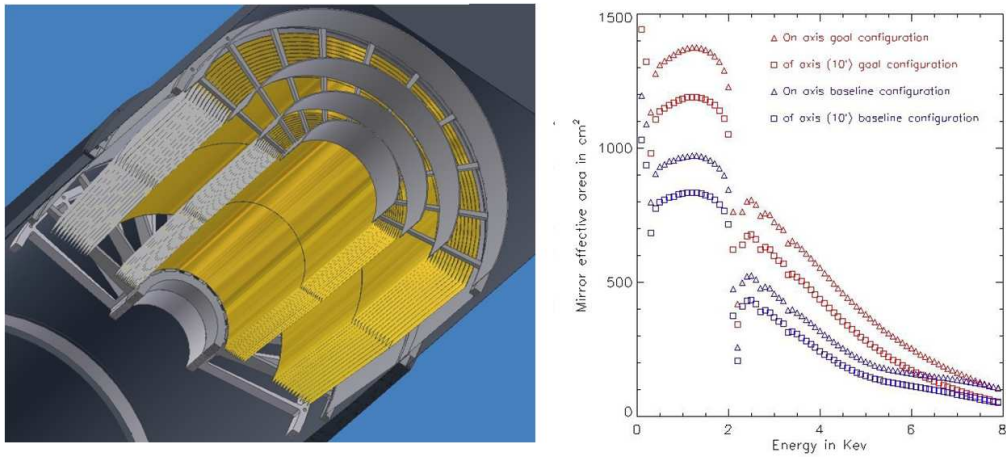

Fig. 4. Detail of the baseline SXI mirrors (left) with the 26 Ni nested shells. The on- and off-axis effective area are shown (right) for this configuration and an improved one based on 36 NiCo shells (see text for details).

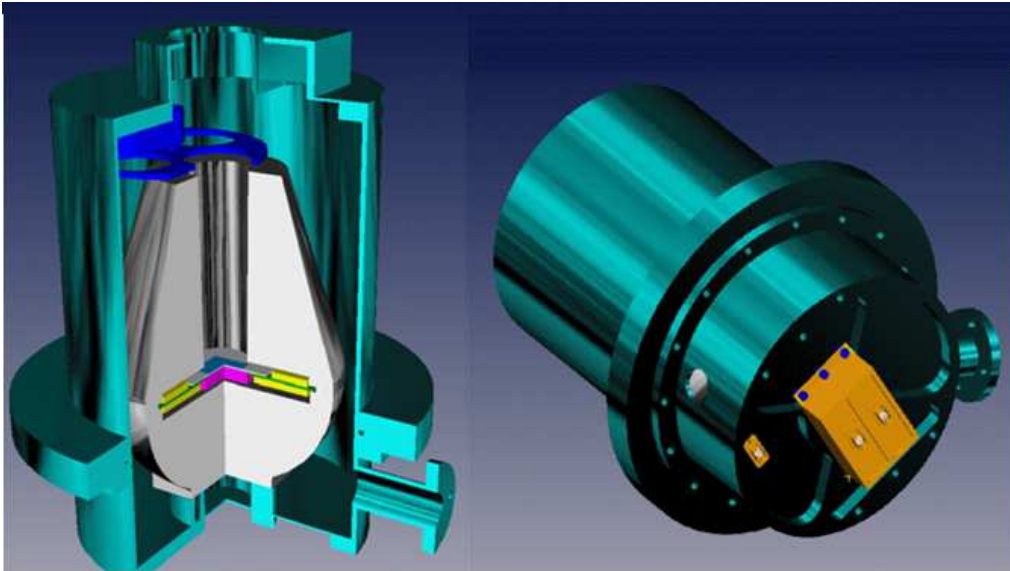

Fig. 5. 3-D view of the inside of the SXI camera (left) and of the external part showing an electronic box (right).

by existing optical catalogs (Della Ceca et al. 2009), like the highly obscured, distant objects. In general SXI will provide unvaluable data during the EXIST followup observations of GRBs and during the inertial pointing observations performed in the second phase of

the mission. These will include SMBHs, transients of all types and GRBs. For GRBs, the detection of spectral features in the afterglow emission can be used in the determination of the redshift, as well as to unveil the structure of the medium surrounding the central engine.

5. Conclusions

The SXI telescope on board EXIST will take full advantage of the operational strategy adopted for the mission, mostly based on surveys and fast follow-up of GRBs and transients. With SXI, EXIST is a real multiwavelength observatory with a sensitive broadband coverage at high energies: 0.1-600 keV. SXI has an effective area of $\sim 950\text{cm}^2$ at 1.5keV. It will perform wide area surveys (scanning and serendipitous) and sensitive observation of transient events in the X-ray (e.g. GRB afterglows, AGN flares). It will also help the identification of HET sources detected during the survey, the characterization of AGN states and the study of the absorbed (even Compton thick) AGN Universe. The heritage of the Swift/XRT, XMM-Newton and INTEGRAL allows to conclude that the SXI performance is appropriate to the profile of the EXIST mission as currently designed. Main improvements of the SXI with respect to Swift/XRT are: a factor ~ 10 effective area and sensitivity, fast detector readout allowing full spectral imaging operation during the scanning survey.

Acknowledgements. We thank the EXIST P.I., Jonathan E. Grindlay for helpful discussions about SXI and acknowledge the support of ASI by grant I/088/06/0.

References

- Bird, A.J. et al. 2010, ApJS, 186, 1
Della Ceca, R. et al. 2009, Proc. of the Workshop "The Extreme Sky: Sampling the Universe above 10 keV", POS, submitted
Grindlay, J. E., et al. 1995, Proc. SPIE, Vol.2518, p.202
Grindlay, J. E., et al. 2008, AIPC, Vol.1133, p.18
Hong, J. et al. 2009, Proc. SPIE, Vol.7435, p.74350A
Strüder, L. and Meidinger, N. 2009, in "The Universe in X-rays", Springer Berlin Heidelberg, eds. J.E. Trümper and G. Hasinger, p.51
Tagliaferri, G. et al. 2009, Proc. SPIE, Vol.7437, p.743706
Tueller, J. et al. 2009, ApJS, in press
Watson, M. et al. 2009, A&A, 493, 339